



UNINTERRUPTIBLE POWER SUPPLY



The SR series on line double conversion UPS with full time Digital Signal Processor control technology is the perfect solution for mission critical users who demand high reliability, availability and performance from a UPS. Input power factor correction, high efficiency and parallel redundant capability provide a superior level of power quality for sensitive electronic equipment and computers loads.

PRINCIPLES OF WORKING

The back up series is composed by: Rectifier, Inverter, Static Switch, manual by-pass and Battery.

The Rectifier-Inverter line normally feeds the users, and the Battery is kept charged by the Rectifier.

If a black out occurs, the Battery supplies power energy to users always through the Inverter. When the black out is over, the Rectifier provides for Battery charge.

If a short circuit or an overload occurs to the users, the Static By-pass switches the load over the emergency line. When the fault is over, the Inverter feeds users.

FEATURES

- Simple Parallel installation;
- Full time Digital Signal Processor Control;
- Filtered, stabilized and regulated sine wave supply;
- High input power factor and low current THD;
- Wide input voltage window and input frequency window, the battery usage is minimized;
- Zero transfer time;
- Add matching battery cabinets and extend the back up time up to several hours. With its isolation conversion technology plus precision control, the optional charger can be installed in parallel up to 4 units;
- Superior overload capability;
- High battery reliability (battery test, manual and automatic);
- LCD display provides real time status and parameter readings;
- Advanced battery discharge management
The ABDM function prevents the deep discharge of the batteries during a power failure.;
- ON LINE – OFF LINE mode settable;
- Optional galvanic isolation transformer;
- RS 232 standard, dry contact, USB, RS485 & SNMP optionals;
- Optional dual input loops;
- Personalizing 60Hz output converter;
- Emergency Power Off.

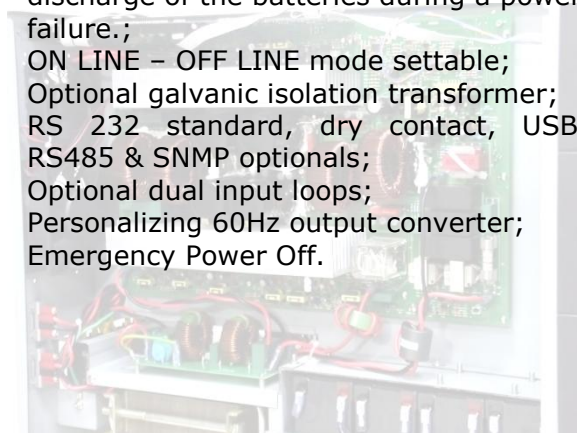

CONTROL PANEL

The front display panel provides all major systems parameters and operational status of the UPS that include full diagnostics for simple, easy servicing. The SPH KING series UPS with DSP control, systematically checks each component and displays the result using on LCD display. This feature allows service technicians the ability to pinpoint and repair the UPS very quickly.

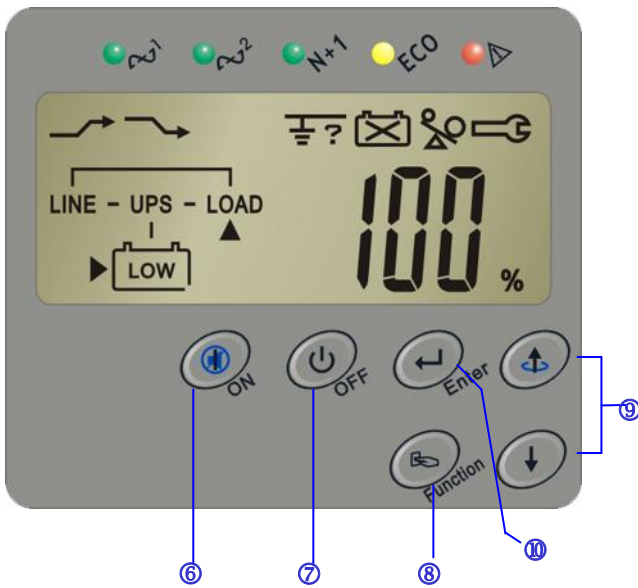

- | | |
|--------------------|----------------------------|
| ■ LED indicators: | ■ Control Keypads: |
| 1 Mains_1 LED | 6 ON (& Alarm Silence) Key |
| 2 Mains_2 LED | 7 OFF Key |
| 3 Redundancy LED | 8 Function Key |
| 4 ECO Mode LED | 9 Scroll Keys |
| 5 Common Alarm LED | 10 Enter Key |

- LCD Display Explanations:
 - ✓ Status
Line Mode, Back up Mode, ECO Mode, Bypass Supply, Battery Low Voltage, Battery Bad/Disconnect, Overload, Transferring with Interruption & UPS fault.
 - ✓ Parameters
AC Voltage, Frequency, Load Percentage, Battery Voltage & Temperature

N+X POWER SCALABLE PARALLEL REDUNDANCY

The standard apparatus to increase the power capacity or configuring a parallel redundant UPS system can be simply interconnected up to 4 units using the CAN-bus RJ45 cables on the rear of the SPH series UPS. The SPH series UPS used an inverter control technology that allows to achieve N+1 scalable redundant power without the use of additional components. The system is fully modular and allows to increase the overall power output, battery runtime, and redundancy as your needs and requirements grow. Parallel

Distribution Box are available till 200 A (40kVA).

INTERFACES

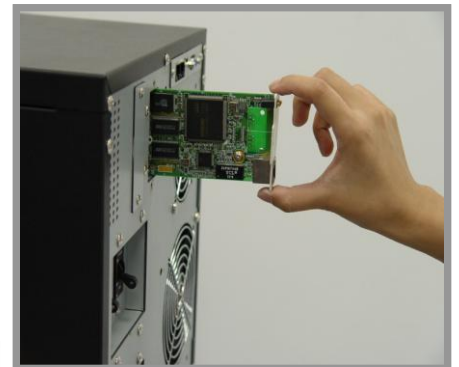

The SR Series UPS also provides two additional customer options communication slots in addition to the standard RS232:

2nd RS232



RS485

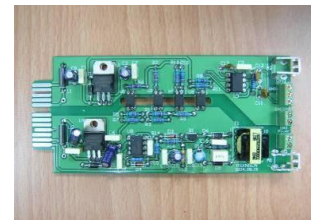

USB



Dry contact



SNMP



REAR PANEL EXPLANATION

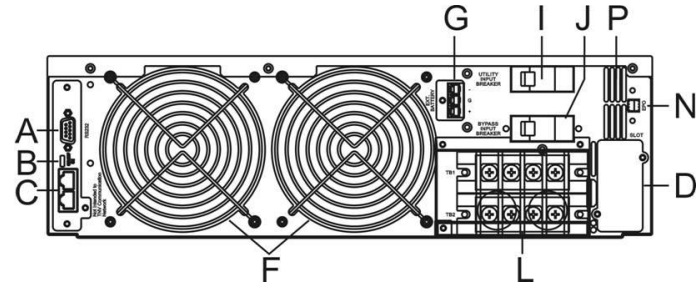

- A) RS232 port
- B) Terminal Resistor for Parallel Function
- C) CAN Bus Connection Port for Parallel System
- D) Customer Options Slot 1
- F) Cooling Fan
- G) External Battery Connector
- I) Utility Input Breaker CB1
- L) Input/Output Terminal Block
- N) EPO (Emergency Power Off)
- P) Air Ventilation Hole

EMERGENCY POWER OFF

The Emergency Power Off facility must use a normally NO contact, which closes to operate the emergency stop procedure. The emergency stop port is located at the rear of the UPS NS module. Through the dry contact interface it is available also a NC contact.

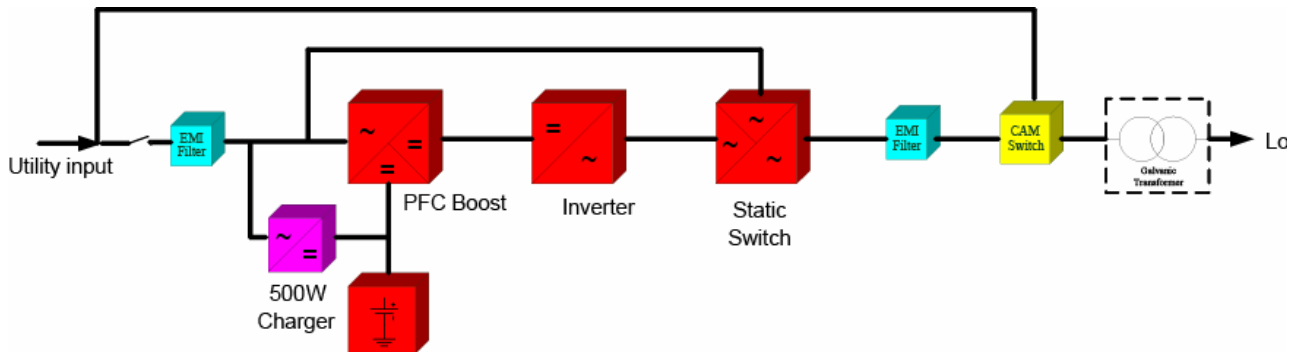

Model	SR4500	SR6000	SR10000	SR10000 3/1
Rated power VA/W	4500/3150	6000/4800	10000/8000	10000/8000
INPUT				
Nominal voltage	230V ± 25% single phase			400V 3Ph+N
Frequency	45 ÷ 66Hz			
Power factor	> 0.98			
Current distortion (THiD)	< 5%			
OUTPUT				
Voltage window	220/230/240V ± 2% single phase, selectable			
Frequency	50Hz or 60Hz ± 0.2%			
Waveform	Sinusoidal			
Voltage distortion (THD)	< 3%			
Transfer time	0 ms.			
Crest factor	3 : 1			
Overload	150% for 1'			
BATTERY				
Type	Sealed Lead Acid maintenance free			
Recharge time	4h at 90%		5h at 90%	
Nominal voltage	240Vdc			
Standard back up time	15'	10'	10'	10'
PROTECTIONS				
Short circuit	Switch off immediately			
Over temperature	Switching by-pass			
Noise suppression	Complies with EN62040-2			
Spike suppression	Complies with EN61000-4-5			
MISCELLANEOUS				
Relative humidity	< 90% without condensing			
Operating temperature	from 0°C to + 40°C			
Noise	< 50 dBA			
Interfaces	RS232 & EPO (dry contact, RS485, USB, SNMP optional)			
Parallel availability	Yes	Yes	Yes	Yes
Heat dissipation	< 450W		< 600W	
Input/output connection	Terminals			
Ext. Battery connection	Plug-in & Play			
Dimensions (mm)	440x176x680	2x 440x550x132	2x 440x680x132	
Weight (kgs)	52	90	130	
STANDARDS				
Safety	EN 62040-1-1, UL1778			
EMC	EN 62040-2, EN 61000-3-2, EN 61000-3-3, FCC classe A			
Marks	CE, cUL, UL			